

BSP Adaptor

RJT Male / BSP Male

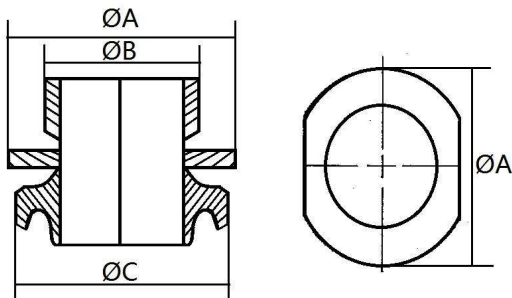

| SIZE | | ØA | ØB | ØC | Code |
|--------|------|-----|------|------|---------|
| Inch | mm | mm | mm | mm | |
| 1" | 25.4 | 50 | 33.7 | 45.7 | A105-10 |
| 1 1/2" | 38.1 | 65 | 48.3 | 58.4 | A105-15 |
| 2" | 50.8 | 75 | 60.3 | 72.7 | A105-20 |
| 2 1/2" | 63.5 | 100 | 76.1 | 85.4 | A105-25 |
| 3" | 76.2 | 110 | 88.9 | 98.1 | A105-30 |

Clamp / BSPT Male

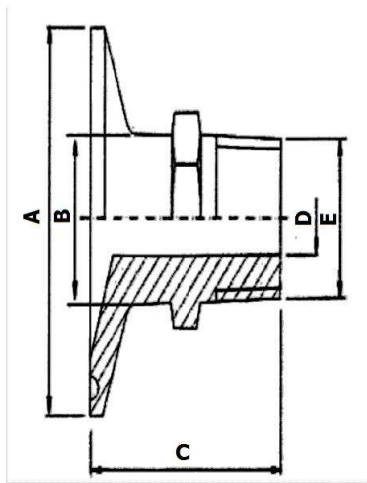

| SIZE | | ØA | ØB | ØC | ØD | ØE | Code |
|---------|------|------|------|----|------|------|----------|
| Clamp | BSPT | | | | | | |
| Inch | Inch | mm | mm | mm | mm | mm | |
| 1"-1.5" | 0.5 | 50.5 | 22.0 | 40 | 9.5 | 21.3 | E105-050 |
| 1"-1.5" | 0.75 | 50.5 | 27.0 | 45 | 15.8 | 26.9 | E105-075 |
| 1"-1.5" | 1 | 50.5 | 34.0 | 50 | 22.2 | 33.7 | E105-10 |
| 1"-1.5" | 1.5 | 50.5 | 38.1 | 50 | 34.9 | 48.3 | E105-15 |
| 2" | 1 | 64.0 | 50.8 | 50 | 22.2 | 33.7 | E105-18 |
| 2" | 1.5 | 64.0 | 50.8 | 50 | 34.9 | 48.3 | E105-19 |
| 2" | 2 | 64.0 | 50.8 | 55 | 47.6 | 60.3 | E105-20 |

BSP Weld Prep

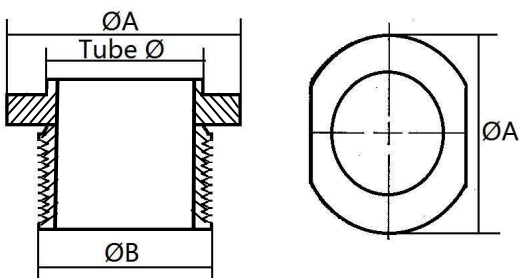

| SIZE | | ØA | ØB | Code |
|--------|-------|-----|------|----------|
| Inch | mm | mm | mm | |
| 0.5" | 12.7 | 28 | 21.3 | S099-05 |
| 0.75" | 19.05 | 37 | 26.9 | S099-075 |
| 1" | 25.4 | 50 | 33.7 | S099-10 |
| 1 1/2" | 38.1 | 65 | 48.3 | S099-15 |
| 2" | 50.8 | 75 | 60.3 | S099-20 |
| 2 1/2" | 63.5 | 100 | 76.1 | S099-25 |
| 3" | 76.2 | 110 | 88.9 | S099-30 |

Note; With our in house fabrication facility we can make a wide range of bespoke adaptors to cater to your individual needs, for more information please contact the sales office.