

# SECTION TWO

## BUTT WELD PIPE FITTINGS

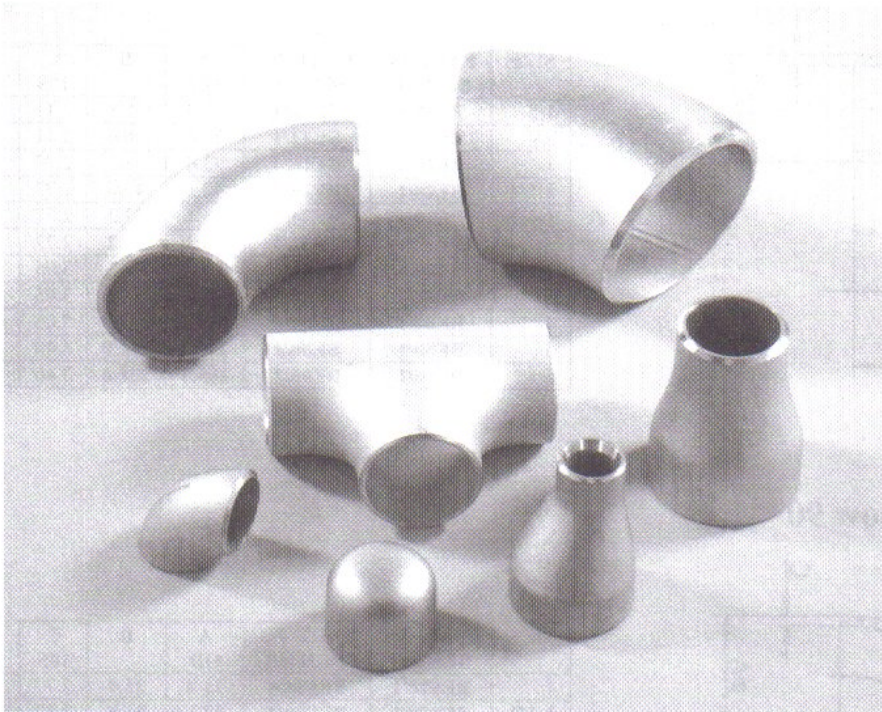

### PRODUCT INFORMATION

- \* 316/L stainless steel welded
- \* Sizes 1/2" to 6" nominal bore
- \* Conforming to ASTM A403, ANSI B16.9, ANSI B16.28 and MSS SP-43
- \* Schedule 10S and 40S wall thickness
- \* Dimensions in mm
- \* Weights in Kg/100
- \* Larger sizes available
- \* Seamless fittings available
- \* Thicker wall sizes available

### INDEX

DESCRIPTION	PAGE	DESCRIPTION	PAGE
Long radius elbow 90°	2.2	Concentric reducer	2.4
Short radius elbow 90°	2.2	Eccentric reducer	2.5
Long radius elbow 45°	2.2	Cap	2.6
Tee	2.2	Stub end	2.6
Reducing tee	2.3		

# BUTT WELD PIPE FITTINGS

## Long Radius Elbow 90°

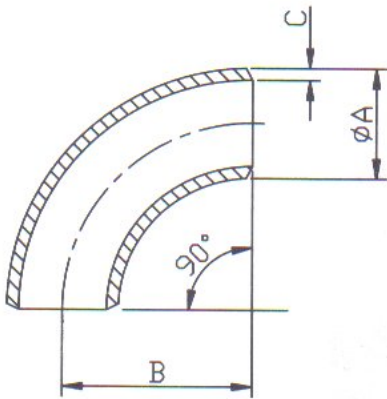

SIZE	PART No SCH 10S	PART No SCH 40S	A OD	B	C 10S	C 40S	Kg/100 SCH 10S	Kg/100 SCH 40S
1/2	BE08/1	BE08/4	21.3	38.1	2.11	2.77	6.1	7.8
3/4	BE12/1	BE12/4	26.6	28.6	2.11	2.87	7.8	10.3
1	BE16/1	BE16/4	33.4	38.1	2.77	3.38	12.8	15.4
1-1/4	BE20/1	BE20/4	42.1	47.6	2.77	3.56	20.6	26.0
1-1/2	BE24/1	BE24/4	48.1	57.2	2.77	3.68	28.3	36.8
2	BE32/1	BE32/4	60.3	76.2	2.77	3.91	47.8	65.2
2-1/2	BE40/1	BE40/4	73.0	95.2	3.05	5.16	81.2	137.0
3	BE48/1	BE48/4	88.9	114.0	3.05	5.49	114.0	204.0
4	BE64/1	BE64/4	114.3	152.0	3.05	6.02	197.0	384.0
5	BE80/1	BE80/4	141.3	191.0	3.40	6.55	342.0	648.0
6	BE96/1	BE96/4	168.3	228.6	3.40	7.11	487.0	994.0

## Short Radius Elbow 90°

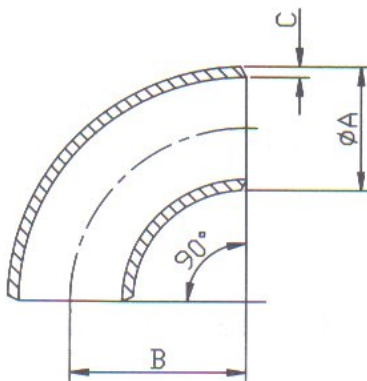

SIZE	PART No SCH10S	PART No SCH40S	A OD	B	C 10S	C 40S	Kg/100 SCH 10S	Kg/100 SCH 40S
1	BES16/1	BES16/4	33.4	25.4	2.77	3.38	9.4	11.8
1-1/4	BES20/1	BES20/4	42.1	31.8	2.77	3.56	15.2	20.4
1-1/2	BES24/1	BES24/4	48.1	38.1	2.77	3.68	18.9	24.5
2	BES32/1	BES32/4	60.3	50.8	2.77	3.91	31.8	43.4
2-1/2	BES40/1	BES40/4	73.0	63.5	3.05	5.16	54.1	90.9
3	BES48/1	BES48/4	88.9	76.2	3.05	5.49	76.1	136.0
4	BES64/1	BES64/4	114.3	101.6	3.05	6.02	131.0	256.0
5	BES80/1	BES80/4	141.3	127.0	3.40	6.55	228.0	432.0
6	BES96/1	BES96/4	168.3	152.4	3.40	7.11	324.0	663.0

## Long Radius Elbow 45°

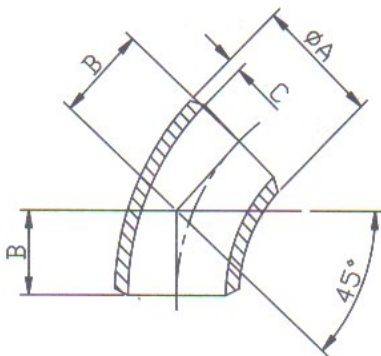

SIZE	PART No SCH10S	PART No SCH40S	A OD	B	C 10S	C 40S	Kg/100 SCH 10S	Kg/100 SCH 40S
1/2	BEA08/1	BEA08/4	21.3	15.88	2.11	2.77	3.0	3.9
3/4	BEA12/1	BEA12/4	26.6	11.13	2.11	2.87	3.9	5.2
1	BEA16/1	BEA16/4	33.4	22.23	2.77	3.38	6.4	7.7
1-1/4	BEA20/1	BEA20/4	42.1	25.4	2.77	3.56	10.3	13.0
1-1/2	BEA24/1	BEA24/4	48.1	28.45	2.77	3.68	14.2	18.4
2	BEA32/1	BEA32/4	60.3	35.05	2.77	3.91	23.9	32.6
2-1/2	BEA40/1	BEA40/4	73.0	44.45	3.05	5.16	40.6	68.3
3	BEA48/1	BEA48/4	88.9	50.80	3.05	5.49	57.1	102.0
4	BEA64/1	BEA64/4	114.3	63.50	3.05	6.02	98.5	192.0
5	BEA80/1	BEA80/4	141.3	79.25	3.40	6.55	171.0	324.0
6	BEA96/1	BEA96/4	168.3	95.25	3.40	7.11	243.0	497.0

## Equal Tees

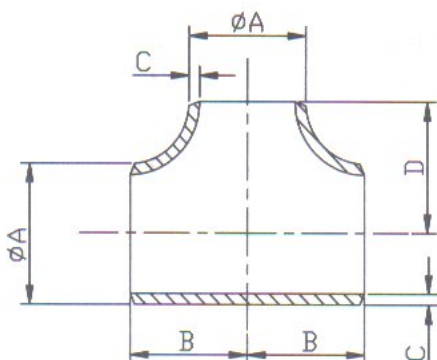

SIZE	PART No SCH10S	PART No SCH40S	A OD	B/D	C 10S	C 40S	Kg/100 SCH 10S	Kg/100 SCH 40S
1/2	BT08/1	BT08/4	21.3	25.40	2.11	2.77	9.0	18.1
3/4	BT12/1	BT12/4	26.6	28.70	2.11	2.87	12.9	25.8
1	BT16/1	BT16/4	33.4	38.10	2.77	3.38	22.3	25.6
1-1/4	BT20/1	BT20/4	42.1	47.75	2.77	3.56	35.6	46.3
1-1/2	BT24/1	BT24/4	48.1	57.15	2.77	3.68	49.7	64.8
2	BT32/1	BT32/4	60.3	63.50	2.77	3.91	68.1	89.3
2-1/2	BT40/1	BT40/4	73.0	76.20	3.05	5.16	120.0	198.0
3	BT48/1	BT48/4	88.9	85.85	3.05	5.49	157.0	261.0
4	BT64/1	BT64/4	114.3	104.9	3.05	6.02	246.0	476.0
5	BT80/1	BT80/4	141.3	124.0	3.40	6.55	404.0	784.0
6	BT96/1	BT96/4	168.3	143.0	3.40	7.11	550.0	954.0



# BUTT WELD PIPE FITTINGS

## Reducing Tees

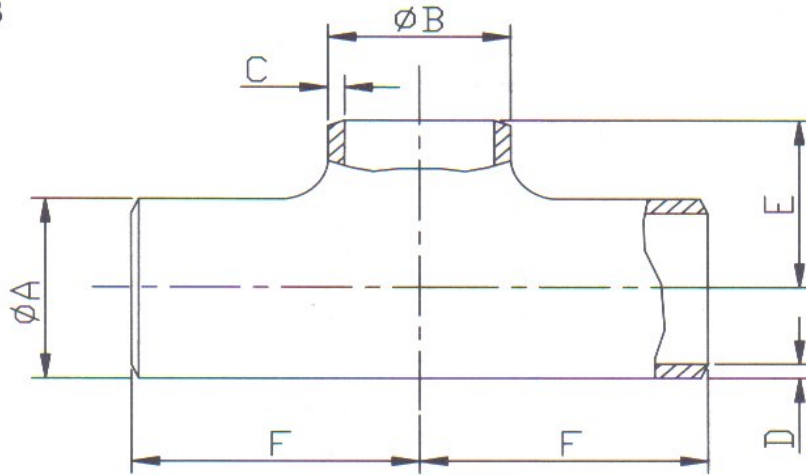

## Sch. 10S

SIZE	PART No	A OD	B OD	C	D	E	F	Kg/100
3/4 X 1/2	BRT1208/1	26.6	21.3	2.11	2.11	28.7	28.7	12.3
1 X 1/2	BRT1608/1	33.4	21.3	2.11	2.77	38.1	38.1	20.4
1 X 3/4	BRT1612/1	33.4	26.6	2.11	2.77	38.1	38.1	21.2
1-1/4 X 1	BRT2016/1	42.1	33.4	2.77	2.77	47.8	47.8	33.9
1-1/2 X 1	BRT2416/1	48.3	33.4	2.77	2.77	57.2	57.2	46.1
1-1/2 X 1-1/4	BRT2420/1	48.3	42.1	2.77	2.77	57.2	57.2	48.2
2 X 1	BRT3216/1	60.3	33.4	2.77	2.77	50.8	63.5	72.5
2 X 1-1/4	BRT3220/1	60.3	42.1	2.77	2.77	57.2	63.5	74.7
2 X 1-1/2	BRT3224/1	60.3	48.3	2.77	2.77	60.5	63.5	76.6
2-1/2 X 1-1/2	BRT4024/1	73.0	48.3	2.77	3.05	66.8	76.2	118.0
2-1/2 X 2	BRT4032/1	73.0	60.3	2.77	3.05	69.9	76.2	121.0
3 X 1-1/2	BRT4824/1	88.9	48.3	2.77	3.05	73.2	79.5	160.0
3 X 2	BRT4832/1	88.9	60.3	2.77	3.05	76.2	85.9	163.0
3 X 2-1/2	BRT4840/1	88.9	73.0	3.05	3.05	82.6	85.9	169.0
4 X 2	BRT6432/1	114.3	60.3	2.77	3.05	88.9	104.9	253.0
4 X 2-1/2	BRT6440/1	114.3	73.0	3.05	3.05	95.3	104.9	259.0
4 X 3	BRT6448/1	114.3	88.9	3.05	3.05	98.6	104.9	261.0
5 X 3	BRT8048/1	141.3	88.9	3.05	3.40	111.3	124.0	417.0
5 X 4	BRT8064/1	141.3	114.3	3.05	3.40	117.6	124.0	424.0
6 X 3	BRT9648/1	168.3	88.9	3.05	3.40	124.0	143.0	575.0
6 X 4	BRT9664/1	168.3	114.3	3.05	3.40	130.3	143.0	585.0
6 X 5	BRT9680/1	168.3	141.3	3.40	3.40	136.7	143.0	592.0

## Sch. 40S

SIZE	PART No	A OD	B OD	C	D	E	F	Kg/100
3/4 X 1/2	BRT1208/4	26.6	21.3	2.77	2.87	28.7	28.7	18.0
1 X 1/2	BRT1608/4	33.4	21.3	2.77	3.38	38.1	38.1	23.4
1 X 3/4	BRT1612/4	33.4	26.6	2.87	3.38	38.1	38.1	24.4
1-1/4 X 1	BRT2016/4	42.1	33.4	3.38	3.56	47.8	47.8	44.1
1-1/2 X 1	BRT2416/4	48.3	33.4	3.38	3.68	57.2	57.2	60.0
1-1/2 X 1-1/4	BRT2420/4	48.3	42.1	3.56	3.68	57.2	57.2	62.9
2 X 1	BRT3216/4	60.3	33.4	3.38	3.91	50.8	63.5	114.0
2 X 1-1/4	BRT3220/4	60.3	42.1	3.56	3.91	57.2	63.5	118.0
2 X 1-1/2	BRT3224/4	60.3	48.3	3.68	3.91	60.5	63.5	123.0
2-1/2 X 1-1/2	BRT4024/4	73.0	48.3	3.68	5.16	66.8	76.2	208.0
2-1/2 X 2	BRT4032/4	73.0	60.3	3.91	5.16	69.9	76.2	212.0
3 X 1-1/2	BRT4824/4	88.9	48.3	3.68	5.49	73.2	79.5	298.0
3 X 2	BRT4832/4	88.9	60.3	3.91	5.49	76.2	85.9	301.0
3 X 2-1/2	BRT4840/4	88.9	73.0	5.16	5.49	82.6	85.9	315.0
4 X 2	BRT6432/4	114.3	60.3	3.91	6.02	88.9	104.9	508.0
4 X 2-1/2	BRT6440/4	114.3	73.0	5.16	6.02	95.3	104.9	522.0
4 X 3	BRT6448/4	114.3	88.9	5.49	6.02	98.6	104.9	527.0
5 X 3	BRT8048/4	141.3	88.9	5.49	6.55	111.3	124.0	813.0
5 X 4	BRT8064/4	141.3	114.3	6.02	6.55	117.6	124.0	836.0
6 X 3	BRT9648/4	168.3	88.9	5.49	7.11	124.0	143.0	1192.0
6 X 4	BRT9664/4	168.3	114.3	6.02	7.11	130.3	143.0	1210.0
6 X 5	BRT9680/4	168.3	141.3	6.55	7.11	136.7	143.0	1234.0

# BUTT WELD PIPE FITTINGS

## Concentric Reducers

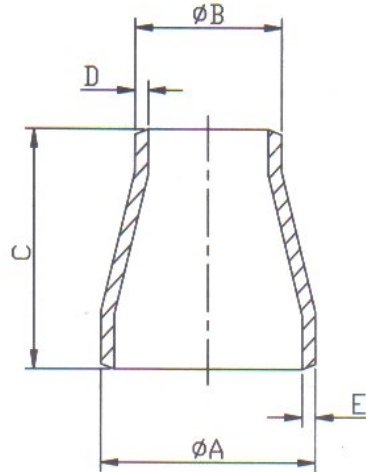

### Sch. 10S

SIZE	PART No	A OD	B OD	C	D	E	Kg/100
3/4 X 1/2	BCR1208/1	26.6	21.3	38.1	2.11	2.11	9.0
1 X 1/2	BCR1608/1	33.4	21.3	50.8	2.11	2.77	9.0
1 X 3/4	BCR1612/1	33.4	26.6	50.8	2.11	2.77	9.8
1-1/4 X 1	BCR2016/1	42.1	33.4	50.8	2.77	2.77	12.5
1-1/2 X 1/2	BCR2408/1	48.3	21.3	63.5	2.11	2.77	15.4
1-1/2 X 3/4	BCR2412/1	48.3	26.6	63.5	2.11	2.77	15.6
1-1/2 X 1	BCR2416/1	48.3	33.4	63.5	2.77	2.77	17.0
1-1/2 X 1-1/4	BCR2420/1	48.3	42.1	63.5	2.77	2.77	19.5
2 X 3/4	BCR3212/1	60.3	26.6	76.2	2.11	2.77	21.4
2 X 1	BCR3216/1	60.3	33.4	76.2	2.77	2.77	23.7
2 X 1-1/4	BCR3220/1	60.3	42.1	76.2	2.77	2.77	25.8
2 X 1-1/2	BCR3224/1	60.3	48.3	76.2	2.77	2.77	27.3
2-1/2 X 1-1/2	BCR4024/1	73.0	48.3	88.9	2.77	3.05	39.6
2-1/2 X 2	BCR4032/1	73.0	60.3	88.9	2.77	3.05	43.2
3 X 1-1/2	BCR4824/1	88.9	48.3	88.9	2.77	3.05	44.4
3 X 2	BCR4832/1	88.9	60.3	88.9	2.77	3.05	47.8
3 X 2-1/2	BCR4840/1	88.9	73.0	88.9	3.05	3.05	54.8
4 X 2	BCR6432/1	114.3	60.3	101.6	2.77	3.05	65.6
4 X 2-1/2	BCR6440/1	114.3	73.0	101.6	3.05	3.05	70.6
4 X 3	BCR6448/1	114.3	88.9	101.6	3.05	3.05	74.8
5 X 3	BCR8048/1	141.3	88.9	127.0	3.05	3.40	120.0
5 X 4	BCR8064/1	141.3	114.3	127.0	3.05	3.40	132.0
6 X 3	BCR9648/1	168.3	88.9	139.7	3.05	3.40	150.0
6 X 4	BCR9664/1	168.3	114.3	139.7	3.05	3.40	162.0
6 X 5	BCR9680/1	168.3	141.3	139.7	3.40	3.40	175.0

### Sch. 40S

SIZE	PART No	A OD	B OD	C	D	E	Kg/100
3/4 x 1/2	BCR1208/4	26.6	21.3	38.1	2.77	2.87	10.5
1 X 1/2	BCR1608/4	33.4	21.3	50.8	2.77	3.38	10.5
1 X 3/4	BCR1612/4	33.4	26.6	50.8	2.87	3.38	11.6
1-1/4 X 1	BCR2016/4	42.1	33.4	50.8	3.38	3.56	15.7
1-1/2 X 1/2	BCR2408/4	48.3	21.3	63.5	2.77	3.68	20.4
1-1/2 X 3/4	BCR2412/4	48.3	26.6	63.5	2.87	3.68	21.0
1-1/2 X 1	BCR2416/4	48.3	33.4	63.5	3.56	3.68	21.9
1-1/2 X 1-1/4	BCR2420/4	48.3	42.1	63.5	3.56	3.68	26.3
2 X 3/4	BCR3212/4	60.3	26.6	76.2	2.87	3.91	29.8
2 X 1	BCR3216/4	60.3	33.4	76.2	3.38	3.91	32.2
2 X 1-1/4	BCR3220/4	60.3	42.1	76.2	3.56	3.91	35.2
2 X 1-1/2	BCR3224/4	60.3	48.3	76.2	3.68	3.91	37.2
2-1/2 X 1-1/2	BCR4024/4	73.0	48.3	88.9	3.68	5.16	66.1
2-1/2 X 2	BCR4032/4	73.0	60.3	88.9	3.91	5.16	68.0
3 X 1-1/2	BCR4824/4	88.9	48.3	88.9	3.68	5.49	78.3
3 X 2	BCR4832/4	88.9	60.3	88.9	3.91	5.49	84.6
3 X 2-1/2	BCR4840/4	88.9	73.0	88.9	5.16	5.49	98.3
4 X 2	BCR6432/4	114.3	60.3	101.6	3.91	6.02	127.0
4 X 2-1/2	BCR6440/4	114.3	73.0	101.6	5.16	6.02	137.0
4 X 3	BCR6448/4	114.3	88.9	101.6	5.49	6.02	145.0
5 X 3	BCR8048/4	141.3	88.9	127.0	5.49	6.55	227.0
5 X 4	BCR8064/4	141.3	114.3	127.0	6.02	6.55	250.0
6 X 3	BCR9648/4	168.3	88.9	139.7	5.49	7.11	304.0
6 X 4	BCR9664/4	168.3	114.3	139.7	6.02	7.11	330.0
6 X 5	BCR9680/4	168.3	141.3	139.7	6.55	7.11	357.0



# BUTT WELD PIPE FITTINGS

## Eccentric Reducers

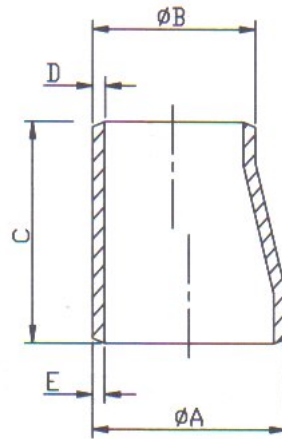

### Sch. 10S

SIZE	PART No	A OD	B OD	C	D	E	Kg/100
3/4 X 1/2	BER1208/1	26.6	21.3	38.1	2.11	2.11	9.0
1 X 1/2	BER1608/1	33.4	21.3	50.8	2.11	2.77	9.0
1 X 3/4	BER1612/1	33.4	26.6	50.8	2.11	2.77	9.8
1-1/4 X 1	BER2016/1	42.1	33.4	50.8	2.77	2.77	12.5
1-1/2 X 1/2	BER2408/1	48.3	21.3	63.5	2.11	2.77	15.4
1-1/2 X 3/4	BER2412/1	48.3	26.6	63.5	2.11	2.77	15.6
1-1/2 X 1	BER2416/1	48.3	33.4	63.5	2.77	2.77	17.0
1-1/2 X 1-1/4	BER2420/1	48.3	42.1	63.5	2.77	2.77	19.5
2 X 3/4	BER3212/1	60.3	26.6	76.2	2.11	2.77	21.4
2 X 1	BER3216/1	60.3	33.4	76.2	2.77	2.77	23.7
2 X 1-1/4	BER3220/1	60.3	42.1	76.2	2.77	2.77	25.8
2 X 1-1/2	BER3224/1	60.3	48.3	76.2	2.77	2.77	27.3
2-1/2 X 1-1/2	BER4024/1	73.0	48.3	88.9	2.77	3.05	39.6
2-1/2 X 2	BER4032/1	73.0	60.3	88.9	2.77	3.05	43.2
3 X 1-1/2	BER4824/1	88.9	48.3	88.9	2.77	3.05	44.4
3 X 2	BER4832/1	88.9	60.3	88.9	2.77	3.05	47.8
3 X 2-1/2	BER4840/1	88.9	73.0	88.9	3.05	3.05	54.8
4 X 2	BER6432/1	114.3	60.3	101.6	2.77	3.05	65.6
4 X 2-1/2	BER6440/1	114.3	73.0	101.6	3.05	3.05	70.6
4 X 3	BER6448/1	114.3	88.9	101.6	3.05	3.05	74.8
5 X 3	BER8048/1	141.3	88.9	127.0	3.05	3.40	120.0
5 X 4	BER8064/1	141.3	114.3	127.0	3.05	3.40	132.0
6 X 3	BER9648/1	168.3	88.9	139.7	3.05	3.40	150.0
6 X 4	BER9664/1	168.3	114.3	139.7	3.05	3.40	162.0
6 X 5	BER9680/1	168.3	141.3	139.7	3.40	3.40	175.0

### Sch. 40S

SIZE	PART No	A OD	B OD	C	D	E	Kg/100
3/4 X 1/2	BER1208/4	26.6	21.3	38.1	2.77	2.87	10.5
1 X 1/2	BER1608/4	33.4	21.3	50.8	2.77	3.38	10.5
1 X 3/4	BER1612/4	33.4	26.6	50.8	2.87	3.38	11.6
1-1/4 X 1	BER2016/4	42.1	33.4	50.8	3.38	3.56	15.7
1-1/2 X 1/2	BER2408/4	48.3	21.3	63.5	2.77	3.68	20.4
1-1/2 X 3/4	BER2412/4	48.3	26.6	63.5	2.87	3.68	21.0
1-1/2 X 1	BER2416/4	48.3	33.4	63.5	3.56	3.68	21.9
1-1/2 X 1-1/4	BER2420/4	48.3	42.1	63.5	3.56	3.68	26.3
2 X 3/4	BER3212/4	60.3	26.6	76.2	2.87	3.91	29.8
2 X 1	BER3216/4	60.3	33.4	76.2	3.38	3.91	32.2
2 X 1-1/4	BER3220/4	60.3	42.1	76.2	3.56	3.91	35.2
2 X 1-1/2	BER3224/4	60.3	48.3	76.2	3.68	3.91	37.2
2-1/2 X 1-1/2	BER4024/4	73.0	48.3	88.9	3.68	5.16	66.1
2-1/2 X 2	BER4032/4	73.0	60.3	88.9	3.91	5.16	68.0
3 X 1-1/2	BER4824/4	88.9	48.3	88.9	3.68	5.49	78.3
3 X 2	BER4832/4	88.9	60.3	88.9	3.91	5.49	84.6
3 X 2-1/2	BER4840/4	88.9	73.0	88.9	5.16	5.49	98.3
4 X 2	BER6432/4	114.3	60.3	101.6	3.91	6.02	127.0
4 X 2-1/2	BER6440/4	114.3	73.0	101.6	5.16	6.02	137.0
4 X 3	BER6448/4	114.3	88.9	101.6	5.49	6.02	145.0
5 X 3	BER8048/4	141.3	88.9	127.0	5.49	6.55	227.0
5 X 4	BER8064/4	141.3	114.3	127.0	6.02	6.55	250.0
6 X 3	BER9648/4	168.3	88.9	139.7	5.49	7.11	304.0
6 X 4	BER9664/4	168.3	114.3	139.7	6.02	7.11	330.0
6 X 5	BER9680/4	168.3	141.3	139.7	6.55	7.11	357.0

# BUTT WELD PIPE FITTINGS

## Caps

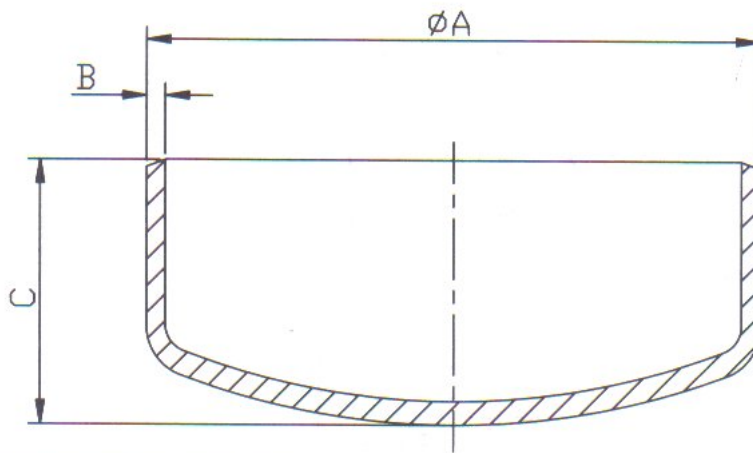

SIZE	PART No SCH10S	PART No SCH40S	A OD	B 10S	B 40S	C	Kg/100 SCH 10S	Kg/100 SCH 40S
1/2	BC08/1	BC08/4	21.3	2.11	2.77	25.4	4.0	4.6
3/4	BC12/1	BC12/4	26.6	2.11	2.87	25.4	5.2	5.9
1	BC16/1	BC16/4	33.4	2.77	3.38	38.1	9.0	10.9
1-1/4	BC20/1	BC20/4	42.1	2.77	3.56	38.1	11.3	14.5
1-1/2	BC24/1	BC24/4	48.1	2.77	3.68	38.1	13.0	17.1
2	BC32/1	BC32/4	60.3	2.77	3.91	38.1	16.8	23.4
2-1/2	BC40/1	BC40/4	73.0	3.05	5.16	50.4	24.2	42.0
3	BC48/1	BC48/4	88.9	3.05	5.49	63.5	36.2	66.4
4	BC64/1	BC64/4	114.3	3.05	6.02	76.2	58.5	117.0
5	BC80/1	BC80/4	141.3	3.40	6.55	88.9	97.8	190.0
6	BC96/1	BC96/4	168.3	3.40	7.11	101.6	135.0	283.0

## Stub Ends MSS Type A

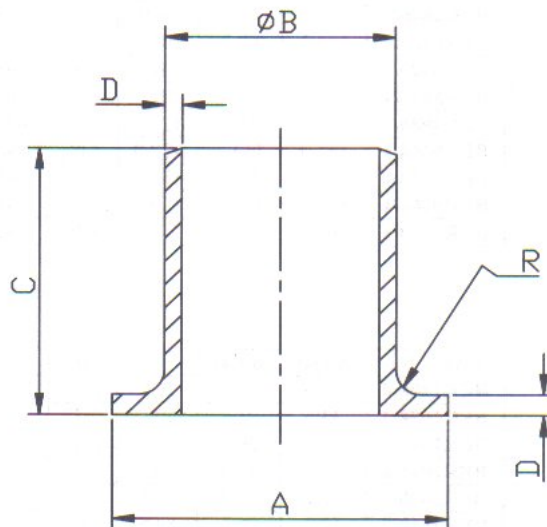

SIZE	PART No SCH10S	PART No SCH40S	A	B OD	C	D 10S	D 40S	R	Kg/100 SCH 10S	Kg/100 SCH 40S
1/2	BSE08/1	BSE08/4	34.9	21.3	50.8	2.11	2.77	3.2	7.7	11.8
3/4	BSE12/1	BSE12/4	42.8	26.6	50.8	2.11	2.87	3.2	8.6	15.4
1	BSE16/1	BSE16/4	50.8	33.4	50.8	2.77	3.38	3.2	14.0	18.6
1-1/4	BSE20/1	BSE20/4	63.5	42.1	50.8	2.77	3.56	4.8	20.8	26.3
1-1/2	BSE24/1	BSE24/4	73.0	48.1	50.8	2.77	3.68	6.4	24.9	37.6
2	BSE32/1	BSE32/4	92.0	60.3	63.5	2.77	3.91	7.9	37.6	53.9
2-1/2	BSE40/1	BSE40/4	104.8	73.0	63.5	3.05	5.16	7.9	47.1	79.7
3	BSE48/1	BSE48/4	127.0	88.9	63.5	3.05	5.49	9.5	63.8	113.3
4	BSE64/1	BSE64/4	157.2	114.3	76.2	3.05	6.02	11.1	97.8	181.2
5	BSE80/1	BSE80/4	185.7	141.3	76.2	3.40	6.55	11.1	123.7	253.7
6	BSE96/1	BSE96/4	215.9	168.3	88.9	3.40	7.11	12.7	195.0	372.0