

Stainless Steel 3-Pce Full Bore Ball Valve threaded BSP

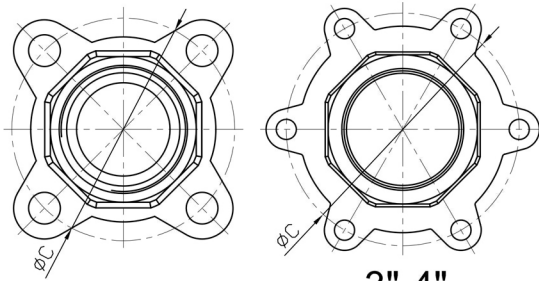
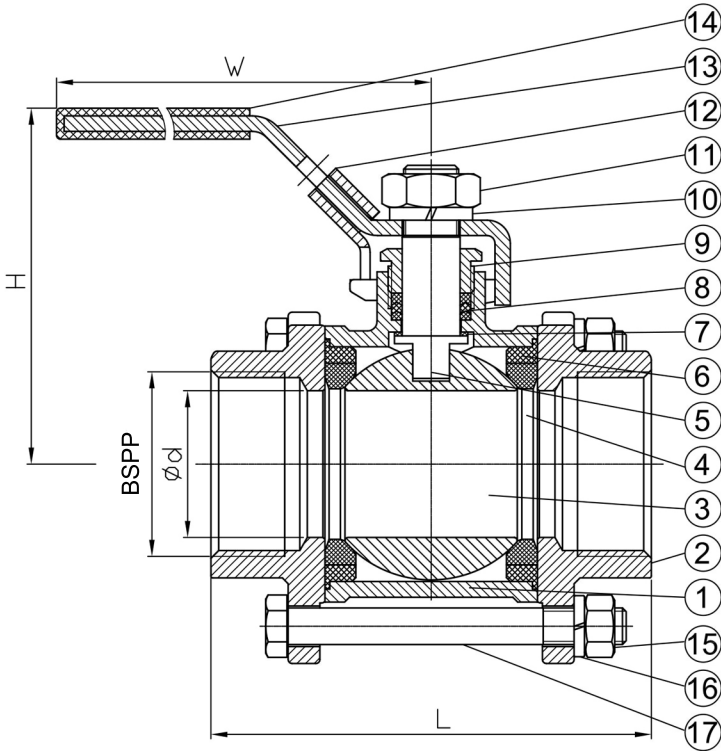

1/4"-2 1/2"

3"-4"

PRESSURE TEMPERATURE RATINGS

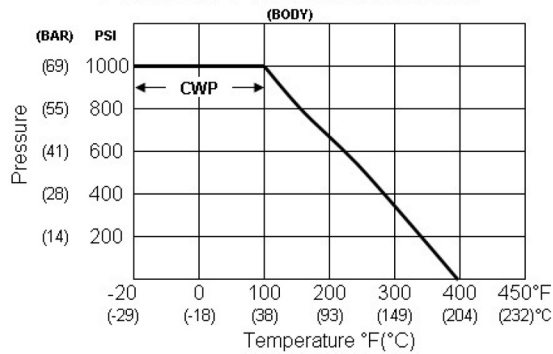

NO.	PART NAME	MATERIAL
1	BODY	CF8M 316
2	CAP	CF8M 316
3	BALL	CF8M 316
4	SEAT	PTFE
5	STEM	SUS316
6	GASKET	PTFE
7	THRUST WASHER	PTFE
8	PACKING	PTFE
9	GLAND	SUS304
10	SPRING WASHER	SUS304
11	STEM NUT	SUS304
12	LOCKING DEVICE	SUS304
13	HANDLE	SUS304
14	PLASTIC COVER	PLASTIC
15	HEX NUT	SUS304
16	BOLT WASHER	SUS304
17	JOINT BOLT	SUS304

Size: 1/4"-4"

Full bore

Threaded ends: ISO 228/1 BSPP

Quality investment casting body and cap

Internal entry blow-out proof stem

Material: CF8M 316

Pressure rating 1000PSI(WOG)

Pressure test: API 598

SIZE BSPP	PART No	d	H	W	L	C	CV FACTOR	Kg
1/4	FBVX04	11	42.5	101.5	50.4	37.5	6	0.44
3/8	FBVX06	12	42.5	101.5	50.4	37.5	7	0.43
1/2	FBVX08	15	49.6	101.5	61.4	45.5	10	0.67
3/4	FBVX12	20	58.1	124	70.2	52.5	25	0.88
1	FBVX16	25	61.3	124	79.6	57.5	35	1.26
1 1/4	FBVX20	32	78.3	152	93	71.5	46	2.04
1 1/2	FBVX24	40	82.5	152	102	79	80	2.80
2	FBVX32	50	90.9	190	124.2	97	110	4.29
2 1/2	FBVX40	65	114.5	242	156.2	124.5	310	8.58
3	FBVX48	75	124	242	179.2	149	360	14.15
4	FBVX64	100	176	327	218.4	180.6	820	25.18