

## 2 Pce Full Bore Ball Valve threaded BSP

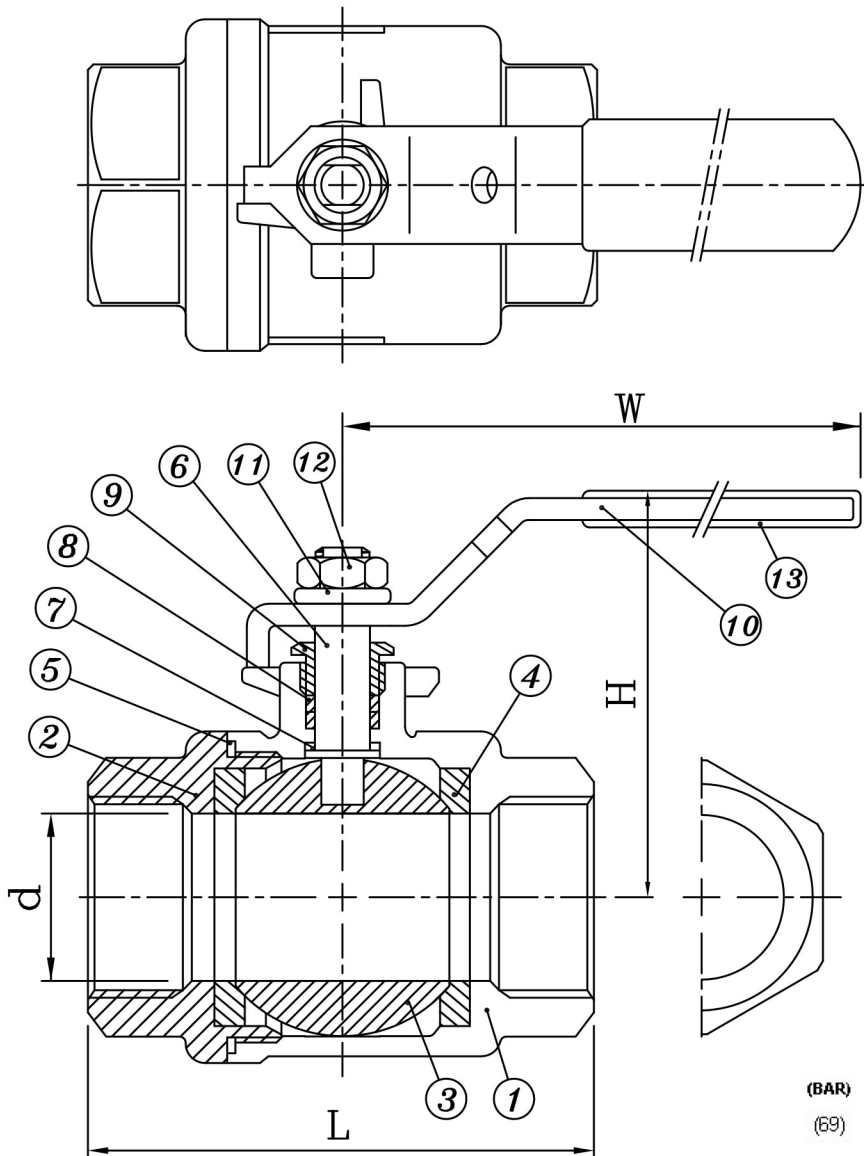

ITEM	PARTS	Q.TY	MATERIAL
1	BODY	1	CF8M 316
2	CAP	1	CF8M 316
3	BALL	1	CF8M 316
4	BALL SEAT	2	PTFE
5	JOINT GASKET	1	PTFE
6	STEM	1	AISI 304
7	THRUST WASHER	1	PTFE
8	STEM PACKING	2	PTFE
9	GLAND NUT	1	AISI 304
10	HANDLE	1	AISI 304
11	SPRING WASHER	1	AISI 304
12	STEM NUT	1	AISI 304
13	PLASTIC COVER	1	PLASTIC

### PRESSURE TEMPERATURE RATINGS

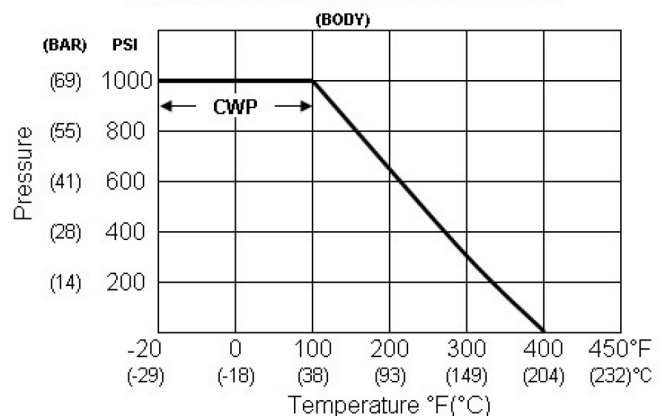

Size: 1/4"-3"  
 Full bore  
 Threaded ends: ISO 228/1 BSP  
 Quality investment casting body and cap  
 Internal entry blow-out proof stem  
 Material: CF8M 316  
 Pressure rating 1000PSI(WOG)  
 Pressure test: API 598

SIZE BSP	PART No	D	L	H	W	CV FACTOR	Kg
1/4	FBV04	11.6	48	48	100	6	0.18
3/8	FBV06	11.6	48	48	100	7	0.19
1/2	FBV08	15	58	52	100	10	0.26
3/4	FBV12	20	65.7	61	127	25	0.4
1	FBV16	25	77	65	127	35	0.59
1 1/4	FBV20	32	90	79	154	46	1.0
1 1/2	FBV24	38	98	83	154	80	1.32
2	FBV32	50	121	97	192	110	2.46
2 1/2	FBV40	65	145	135	244	310	4.83
3	FBV48	80	166	144	244	360	7.45